

S t r e n g t h f r o m t h e C o r e

nekoosa digital laminated paper



Protect your creative ideas with

Nekoosa Digital Laminated Papers



Suitable for most digital (laser) printing, as well as commercial printing and ink jet compatible

Premium Tear-Resistant Digital Laminated Papers

Developed with the benefits of real paper yet tear-resistant, Nekoosa Digital Laminated Papers is a paper-film-paper construction provided in both coated and uncoated grades, and in several digital sheet sizes.

- End-use applications include integrated ID cards, tags, licenses, index tab dividers, shelf-talkers, point-of-sale signs, menus and phone cards
- **Custom order sizes, including folio sheets, as well as pre-punched converting options available.**

With new Nekoosa Digital Laminated Papers, customers benefit from the following advantages:

- High tear strength
- Prints and converts like standard paper
- No excessive drying times
- Regular press set up procedures
- Readily accepts scoring/folding, die cutting/perforating, embossing, sewing and coating/laminating

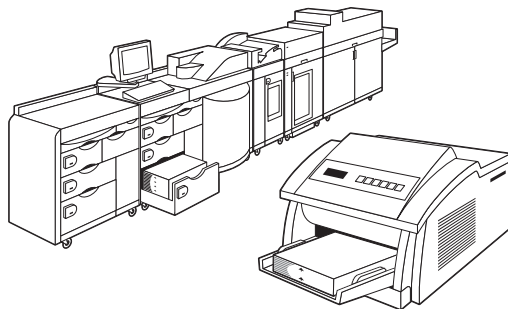

Nekoosa's Digital Laminated Paper is constructed using three layers.

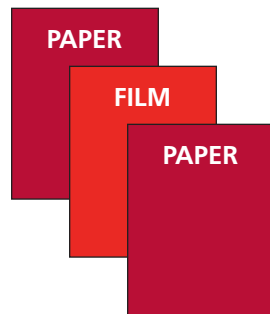

GRADE	SHEET SIZE	SHEETS/CARTON
4.5 Pt. Uncoated	8.5" x 11"	2,500
	12" x 18"	1,500
6.9 Pt. Uncoated	8.5" x 11"	1,500
	12" x 18"	1,000
5.3 Pt. CS2	8.5" x 11"	2,000
	12" x 18"	1,250

For more information on Nekoosa Digital Laminated Papers, contact your local distributor, sales representative or call us at 800-826-4886.

841 Market Street, Nekoosa, WI 54457 • 1-800-826-4886 • 1-800-552-2039 fax • www.nekoosacoated.com

Innovations in Paper

WARRANTY - Nekoosa Coated Products warrants that this product meets specifications at the time of purchase. Nekoosa's entire liability and your exclusive remedy under this warranty is, at Nekoosa's option, either (a) replacement of the product, or (b) refund of the purchase price of the product, which must be returned to Nekoosa with proof of purchase within 60 days of discovery. This warranty does not apply to failure of the product resulting in misuse, abuse, accident, neglect or mishandling, improperly adjusted or maintained printers, incorrect environments, or wear from ordinary use.

THIS WARRANTY IS MADE IN LIEU OF OTHER RIGHTS, CONDITIONS AND WARRANTIES, EXPRESS OR IMPLIED, INCLUDING BUT NOT LIMITED TO THE IMPLIED WARRANTIES OF MERCHANTABILITY AND FITNESS FOR A PARTICULAR PURPOSE.

LIMITATION OF LIABILITY: NEKOOSA COATED PRODUCTS SHALL NOT BE LIABLE FOR ANY DIRECT, INDIRECT, SPECIAL CONSEQUENTIAL OR INCIDENTAL LOSS OR DAMAGE (INCLUDING WITHOUT LIMITATION DAMAGES FOR LOSS OF PROFITS, REVENUES, OR BUSINESS) IN ANY WAY RELATED TO THE PRODUCT.